

R1 – Series Reverse Osmosis Systems

R1 – Series Reverse Osmosis Systems are designed for overall superior performance, high recovery rates, minimal energy consumption and offer great savings with low maintenance and operation costs.

R1 – Series Reverse Osmosis Systems feature a new, innovative and expandable design. These systems feature only the highest quality components, including a programmable computer controller with many built-in standard features, a stainless steel booster pump for high performance and corrosion resistance, ultra low energy membranes and fiberglass membrane housings for enhanced performance and durability.

R1 – Series Reverse Osmosis Systems have been engineered for capacities ranging from 1,500 – 21,600 gallons per day.

R1 – 6140
Reverse Osmosis System



Benefits

- Fully Equipped and Customizable
- Components Easily Accessible
- Easy Maintenance and Servicing
- Expandable System and Skid Mounted
- Pre-Plumbed, Wired and Assembled
- 20% Less Energy
- Decreased Size of Dimensional Footprint
- Individually Tested and Preserved
- 1-Year Limited Warranty
- Low Operation and Maintenance Costs

Know Higher Standards™

Standard Features

- C – 22 Computer Controller
 - LED Display
 - Pre-Treatment Lockout
 - Tank Level Input
 - Low Pressure Monitoring and Alarm
 - TDS Monitoring
 - Feed Flush
- AXEON Permeate and Concentrate Flow Meters
- AXEON Concentrate Recycle with Flow Meter
- Permeate Sample Valves R1 – 1140 through R1 – 6140
- AXEON Pre-Filter 0 – 100 psi Panel Mounted Glycerin Filled Gauges
- AXEON Pump Discharge and Concentrate 0 – 300 psi Panel Mounted Glycerin Filled Gauges
- AXEON 5 – Micron Sediment Pre-Filter
- AXEON HF5 – Series Ultra Low Energy Membrane Elements
- AXEON Fiberglass Membrane Housings – 300 psi
- AXEON by Pentek® 20" Big Grey Cartridge Housings
- Goulds® Multi-Stage Stainless Steel Booster Pump
- ASCO™ Composite Feed Solenoid Valve
- Feed Low Pressure Switch
- White Powder Coated Aluminum Frame



R1 – 6140
Reverse Osmosis System

Options and Upgrades

- S150 Microprocessor Controller
- S150 Expander Board
- S150 Dual TDS Board and Sensor
- Filmtec® LCLE Membrane Elements
- Filmtec® LCHR Membrane Elements
- AXEON Stainless Steel Membrane Housings
- AXEON NF3 – Membrane Elements
- AXEON NF4 – Membrane Elements
- AXEON HR3 – Membrane Elements
- Hanna® BL 981411 pH Controller
- Chemical Pump Outlet
- Pump Pressure Relief Valve
- Blending Valve
- Permeate Divert Valve
- High Pressure Tank Switch
- Caster Wheels
- Wooden Crate

AXEON Naming Matrix

	R1	6	1	40
R-SERIES MODEL				
R1 Tap Water Model				
HOUSING QUANTITY DESIGNATION				
1 1 Vessel				
2 2 Vessel				
3 3 Vessel				
4 4 Vessel				
5 5 Vessel				
6 6 Vessel				
8 8 Vessel				
10 10 Vessel				
12 12 Vessel				
MEMBRANE QUANTITY PER HOUSING				
1 1 Membrane				
4.0 INCH MEMBRANE DIAMETER				

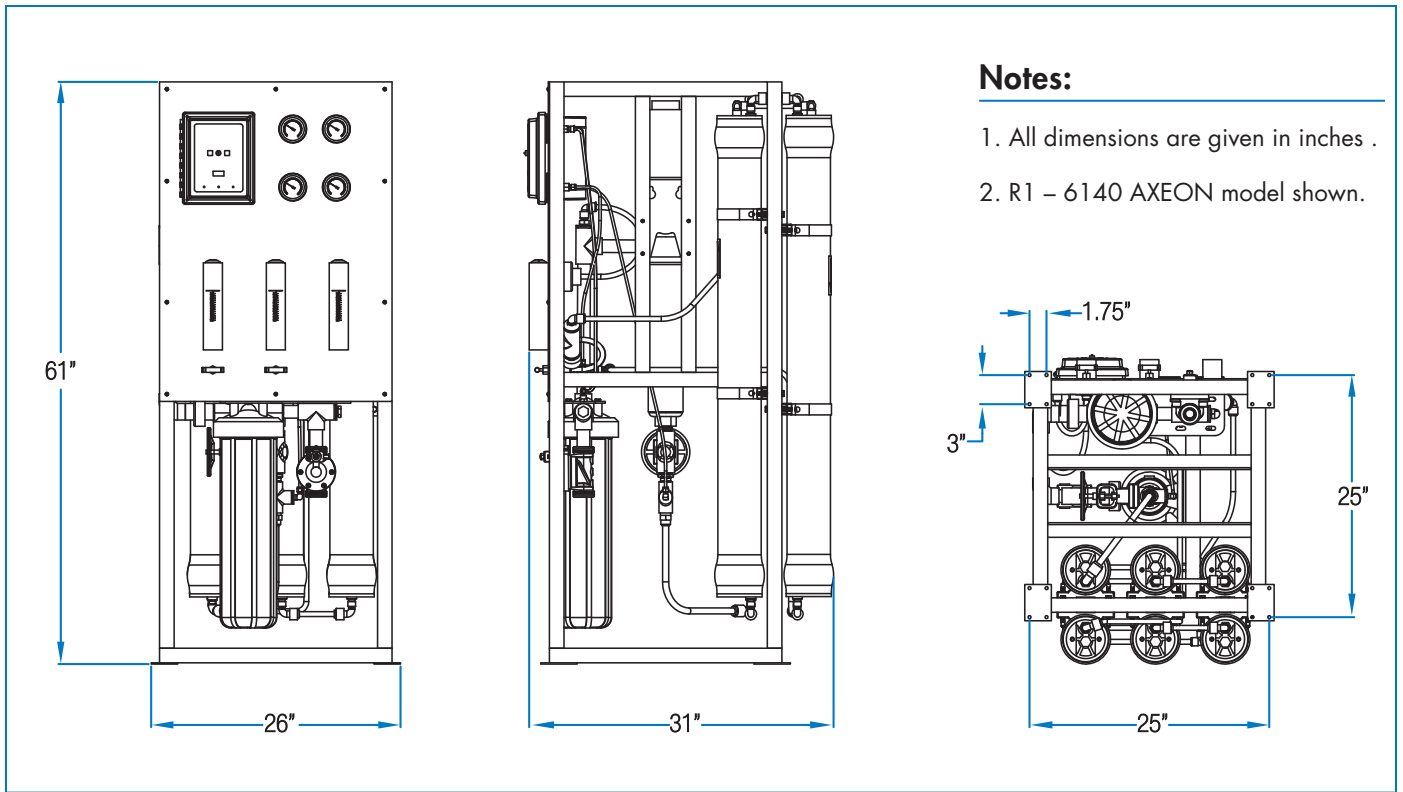

Notes:

1. All dimensions are given in inches .
2. R1 – 6140 AXEON model shown.

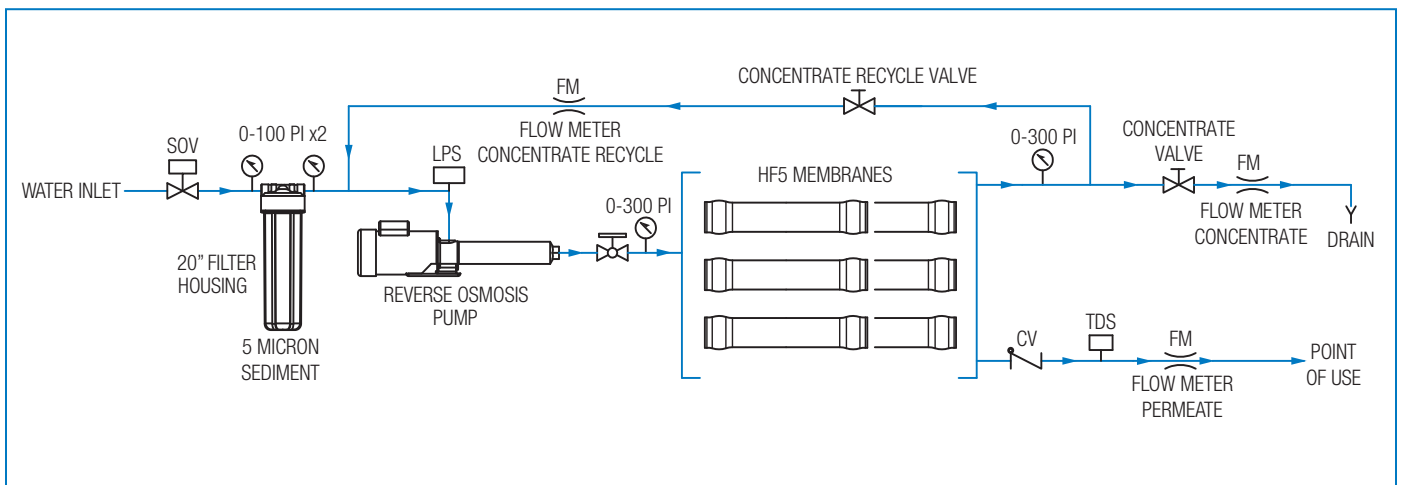

Array Specifications

Model	Vessel Array	Vessel Size	Vessel Quantity	Membrane Size	Membrane Quantity
R1 – 1140	1	4040	1	4040	1
R1 – 2140	1:1	4040	2	4040	2
R1 – 3140	1:1:1	4040	3	4040	3
R1 – 4140	1:1:1:1	4040	4	4040	4
R1 – 5140	1:1:1:1:1	4040	5	4040	5
R1 – 6140	1:1:1:1:1:1	4040	6	4040	6
R1 – 8140	2:2:2:2	4040	8	4040	8
R1 – 10140	2:2:2:2:2	4040	10	4040	10
R1 – 12140	2:2:2:2:2:2	4040	12	4040	12

AXEON R1 – Series Reverse Osmosis Systems

Product Specifications									
Models	R1 – 1140	R1 – 2140	R1 – 3140	R1 – 4140	R1 – 5140	R1 – 6140	R1 – 8140	R1 – 10140	R1 – 12140
Design									
Configuration	Single Pass	Single Pass	Single Pass	Single Pass	Single Pass	Single Pass	Single Pass	Single Pass	Single Pass
Feedwater TDS max (ppm) [†]	2,000	2,000	2,000	2,000	2,000	2,000	2,000	2,000	2,000
Standard Recovery %	50 – 75	50 – 75	50 – 75	50 – 75	50 – 75	50 – 75	50 – 75	50 – 75	50 – 75
Rejection and Flow Rates^{†††}									
Permeate Flow Rate (gpd / lpd)	1,800 / 6,813	3,600 / 13,627	5,400 / 20,441	7,200 / 27,254	9,000 / 34,068	10,800 / 40,882	14,400 / 54,509	18,000 / 68,137	21,600 / 81,764
Permeate Flow Rate (gpm / lpm)	1.25 / 4.73	2.50 / 9.46	3.75 / 14.19	5.00 / 18.93	6.25 / 23.66	7.50 / 28.39	10.00 / 37.85	12.50 / 47.32	15.00 / 56.78
Concentrate Flow Rate (gpm / lpm)	3 / 11.35	3 / 11.35	3 / 11.35	3 / 11.35	3 / 11.35	3 / 11.35	6 / 22.71	6 / 22.71	6 / 22.71
Concentrate Recycle Flow Rate (gpm / lpm)	Up to 5 / 18.93	Up to 5 / 18.93	Up to 5 / 18.93	Up to 5 / 18.93	Up to 5 / 18.93	Up to 5 / 18.93	Up to 5 / 18.93	Up to 5 / 18.93	Up to 5 / 18.93
Connections									
Feed Connection (in)	1 FNPT	1 FNPT	1 FNPT	1 FNPT	1 FNPT	1 FNPT	1 FNPT	1 FNPT	1 FNPT
Permeate Connection (in)	3/4 FNPT	3/4 FNPT	3/4 FNPT	1 FNPT	1 FNPT	1 FNPT	1 FNPT	1 FNPT	1 FNPT
Concentrate Connection (in)	3/4 FNPT	3/4 FNPT	3/4 FNPT	1 FNPT	1 FNPT	1 FNPT	1 FNPT	1 FNPT	1 FNPT
Membranes									
Membrane(s) Per Vessel	1	1	1	1	1	1	1	1	1
Membrane Quantity	1	2	3	4	5	6	8	10	12
Membrane Size	4040	4040	4040	4040	4040	4040	4040	4040	4040
Nominal TDS Rejection %	98.5	98.5	98.5	98.5	98.5	98.5	98.5	98.5	98.5
Vessels									
Vessel Array	1	1:1	1:1:1	1:1:1:1	1:1:1:1:1	1:1:1:1:1:1	2:2:2:2	2:2:2:2:2	2:2:2:2:2:2
Vessel Quantity	1	2	3	4	5	6	8	10	12
Pumps									
Pump Type	Multi-Stage	Multi-Stage	Multi-Stage	Multi-Stage	Multi-Stage	Multi-Stage	Multi-Stage	Multi-Stage	Multi-Stage
Motor HP	1.5	1.5	1.5	1.5	3	3	3	3	3
RPM at 60	3450	3450	3450	3450	3450	3450	3450	3450	3450
Electrical									
Standard Voltage + Amp Draw	220V 60HZ 1PH 8.8A**	220V 60HZ 1PH 8.8A**	220V 60HZ 1PH 8.8A**	220V 60HZ 1PH 8.8A**	220V 60HZ 1PH 16A**	220V 60HZ 1PH 16A**	220V 60HZ 1PH 16A**	220V 60HZ 1PH 16A**	220V 60HZ 1PH 16A**
Systems Dimensions									
Approximate Dimensions* L x W x H (in / cm)	29 x 26 x 61 / 73.66 x 66.04 x 154.94	29 x 26 x 61 / 73.66 x 66.04 x 154.94	29 x 26 x 61 / 73.66 x 66.04 x 154.94	31 x 26 x 61 / 78.74 x 66.04 x 154.94	31 x 26 x 61 / 78.74 x 66.04 x 154.94	31 x 26 x 61 / 78.74 x 66.04 x 154.94	33 x 50 x 61 / 83.82 x 127 x 154.94	33 x 50 x 61 / 83.82 x 127 x 154.94	33 x 50 x 61 / 83.82 x 127 x 154.94
Approximate Weight (lbs / kg)	250 / 113.40	290 / 131.54	330 / 149.68	370 / 167.83	430 / 195.05	470 / 213.19	510 / 231.33	550 / 249.48	590 / 267.62

Test Parameters: 550 TDS Filtered (5 – Micron), Dechlorinated, Municipal Feedwater, 65 psi / 4.50 bar Feed Pressure, 80 / 5.5 psi / 10.34 bar Operating Pressure, 77°F / 25°C, Recovery as stated, 7.0 pH. Data taken after 60 minutes of operation.

* Does not include operating space requirements.

** Varies with motor manufacturer.

Operating Limits^{††}

Maximum Feed Temperature (°F / °C)	85 / 29	Maximum Free Chlorine ppm	0
Minimum Feed Temperature (°F / °C)	40 / 4	Maximum TDS ppm	2,000
Maximum Ambient Temperature (°F / °C)	120 / 49	Maximum Hardness gpg	0
Minimum Ambient Temperature (°F / °C)	40 / 4	Maximum pH (Continuous)	11
Maximum Feed Pressure (psi / bar)	85 / 6	Minimum pH (Continuous)	2
Minimum Feed Pressure (psi / bar)	45 / 3	Maximum pH (Cleaning 30 Min.)	13
Maximum Pressure (psi / bar)	200 / 14	Minimum pH (Cleaning 30 Min.)	1
Maximum Feed Silt Density Index (SDI)	<3	Maximum Turbidity NTU	1

† Low temperatures and feedwater quality, such as high TDS levels will significantly affect the systems production capabilities and performance. Computer projections must be run for individual applications which do not meet or exceed minimum and maximum operating limits for such conditions.

†† System pressure is variable due to water conditions. Permeate flow will increase at a higher temperature and will decrease at a lower temperature.

††† Product flow and maximum recovery rates are based on feedwater conditions as stated above. Do not exceed recommended permeate flow.

Design conditions are not identical to test conditions, please contact the manufacturer or your supplier for more information.

